

EN

QUICK START GUIDE

Motorised Infrared
Optical Beam
Smoke Detector

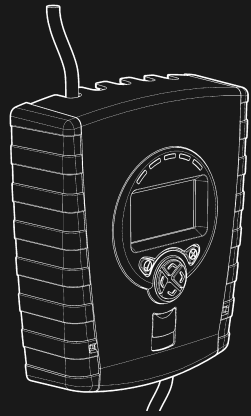
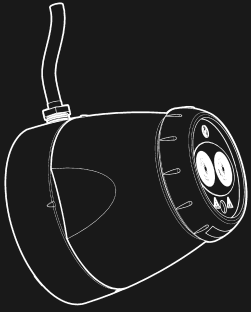

Document Number: 0044-033-02-EN

1. General Information

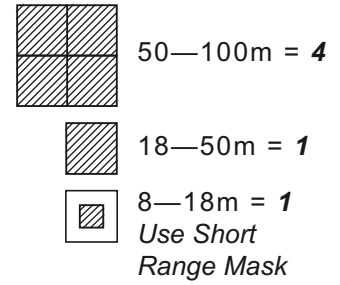
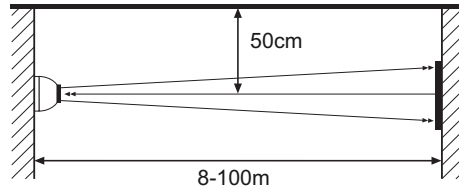
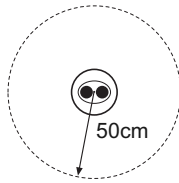

Ensure clear line of sight from Detector to Reflector

Mount on solid surfaces (structural wall or girder)

- Check the beam spacing against local regulations
- Position beam as high as possible, but with a minimum distance of 0.5m from Detector to ceiling
- Mount Detector and Reflector directly opposite each other
- Do NOT position Detector where personnel or objects can enter the beam path
- Do NOT position 2 Detectors facing each other
- LED indicator must face downward

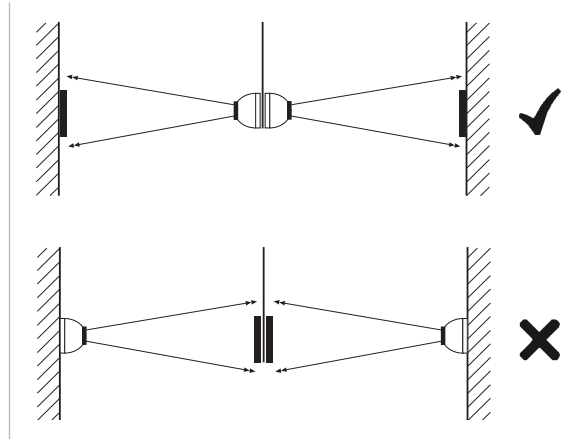

2. Wiring Diagrams

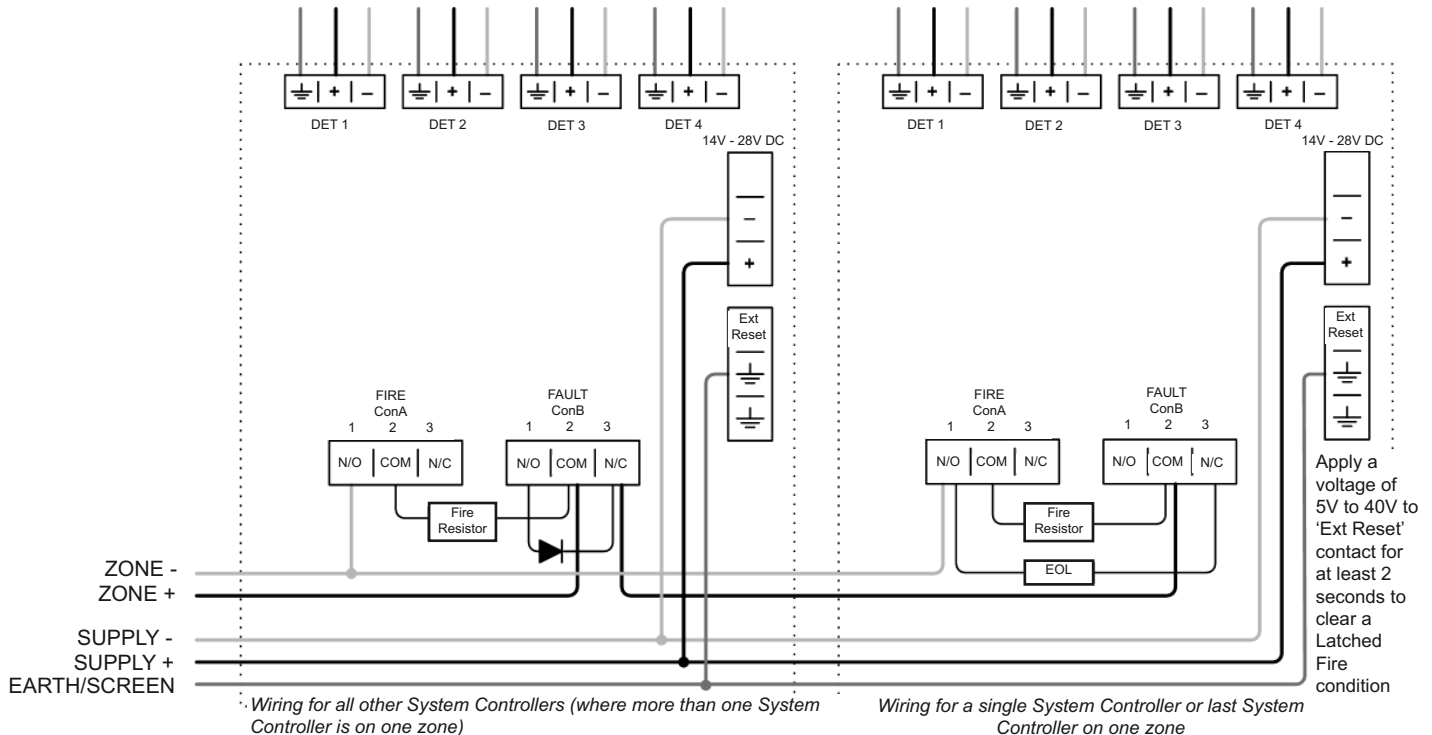

- Check operation of Fire and Fault connection on Fire Panel
- ALWAYS use a separate screened 2-core cable for each detector head
- CAUTION: For system monitoring – Do not use looped wire under any terminals. Break wire run to provide monitoring of connections

Components not supplied (Check Fire Control Panel manufacturer for values):

- Fire Resistor (Some Zone and Switch Interface Modules do not need a Fire Resistor - replace Resistor with a short circuit.)
- Detector Continuity Diode
- End Of Line ('EOL') component

3. Fitting the Product

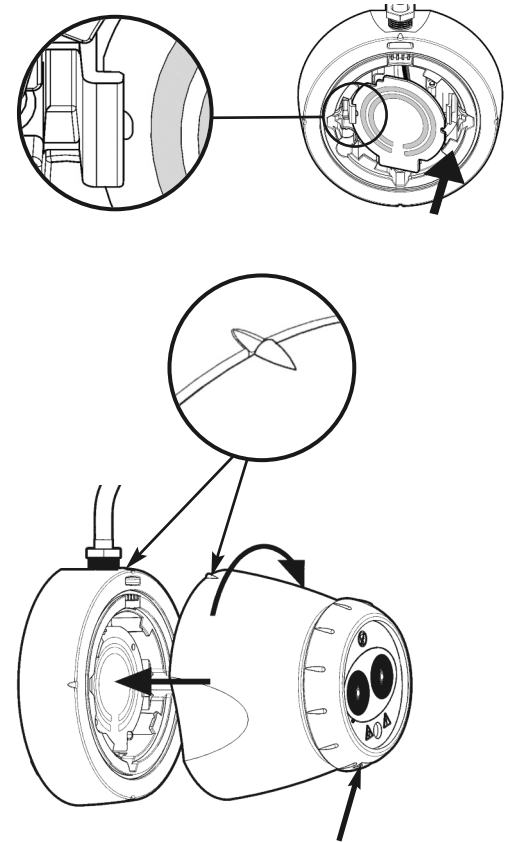
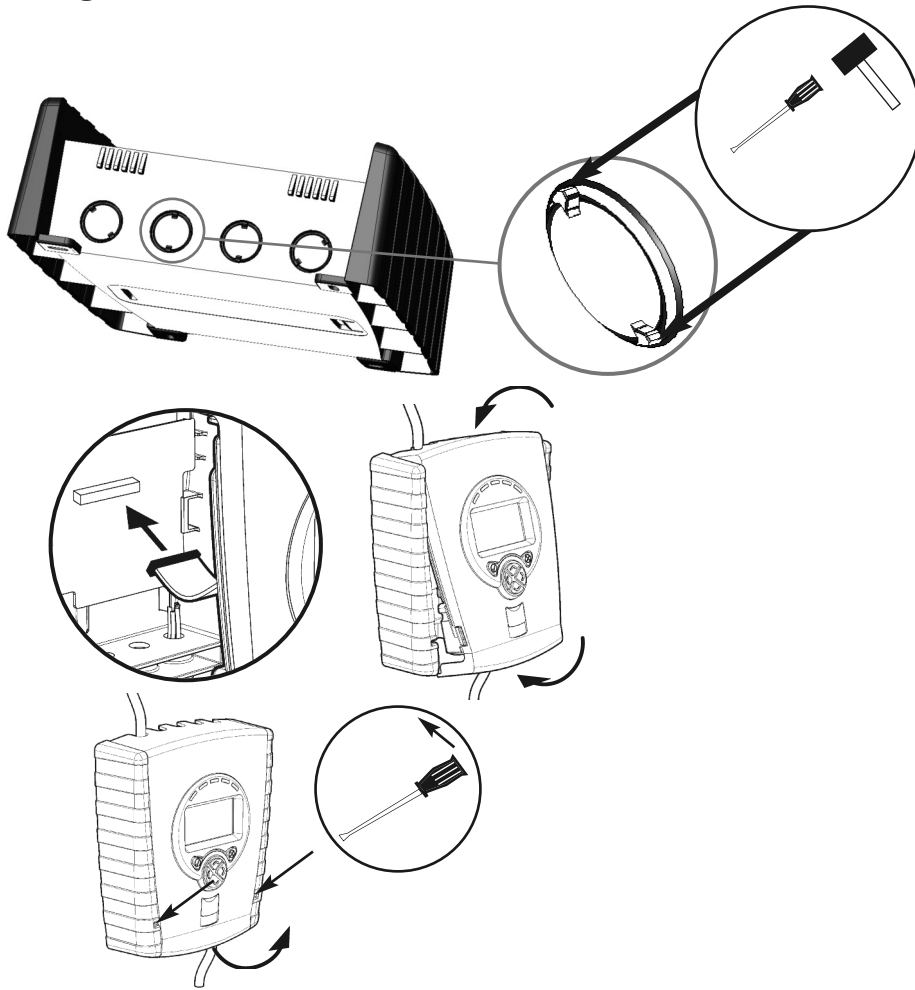

LED indicator must face downward

One System Controller can be used to control and monitor up to four Detector heads. The '#' symbol in this guide is used to represent the number of the Detector currently selected (1, 2, 3 or 4).

4. Apply power

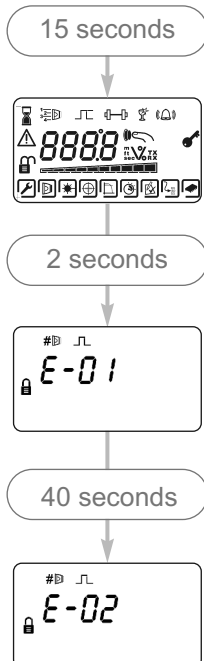

• 'E-02' at this stage is normal

5. Enter Pass Code to Access Engineering Menu

Press ✓ for Pass Code screen:

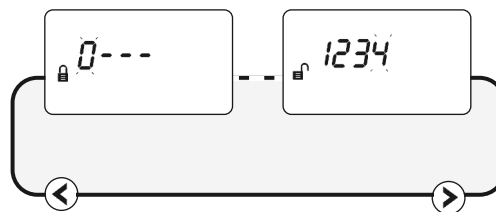

- Default Pass Code: 1 2 3 4
- ▲ ▼ Change digit
- ◀ ▶ Move between digits
- ✓ Accept
- An incorrect Pass Code will return the display to the Pass Code entry screen
- Three incorrect attempts will lock access for three minutes

6. Find Detectors

- 'Find' is automatically displayed the first time this process is run. 'Find' can also be accessed in the System Controller settings menu

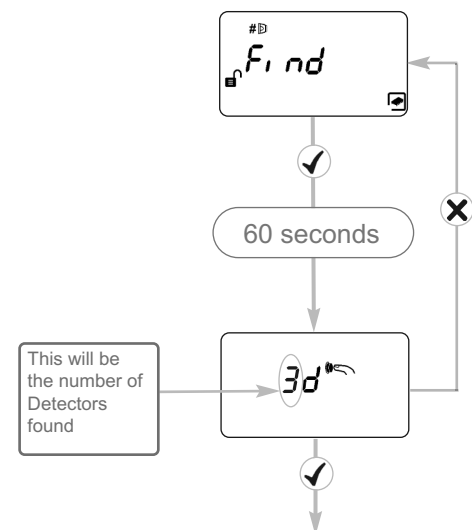

- Press tick to enable 'Found' Detectors
- Any unused Detector channels are switched off
- Press X to re-scan if number is incorrect

7. Select Power Mode

- All functions can be performed in 'Lo A' mode (default) (10, 12, 14 or 16 mA for 1, 2, 3 or 4 Detectors found)
- The system will default to 'Lo A' mode when power is applied
- Select 'Hi A' (50mA) to enable faster beam movement during Auto-Align, Hand Align and Laser Targeting
- After installation, set the system back to 'Lo A'

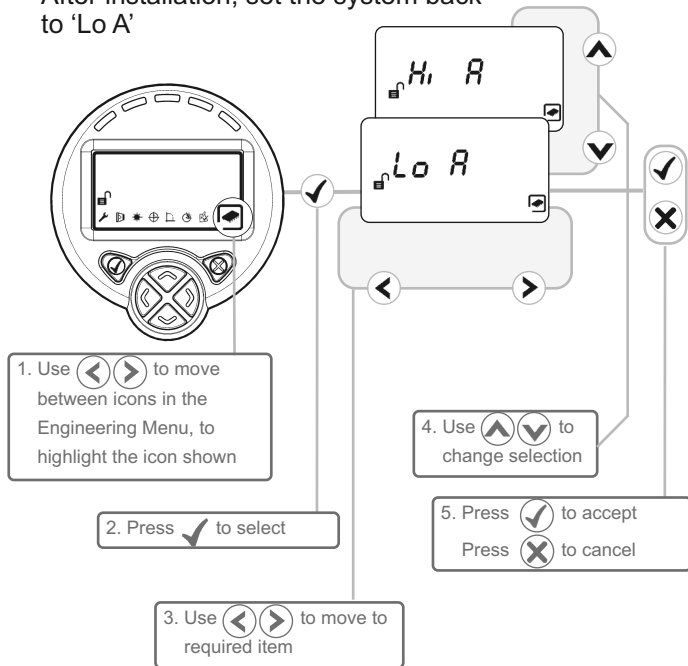

10. LASER Targeting

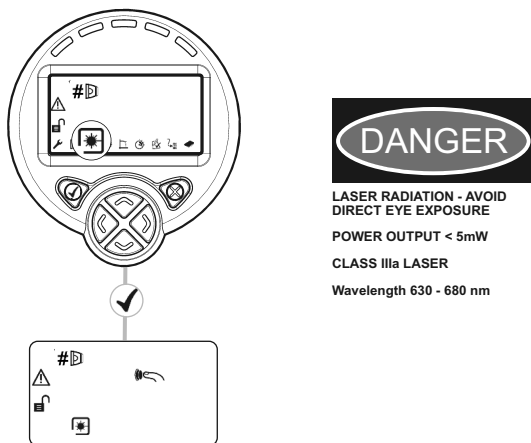

The system will signal Fault while in this mode

The LASER is used to align the Detector with the Reflector. It is an approximate alignment tool only. After Auto-Align the LASER will not necessarily be pointing on the Reflector

- Use \leftarrow \rightarrow \uparrow \downarrow to move the LASER as close to the Reflector as possible
- One press of an arrow key results in one movement of the Detector head
- Press \checkmark or \times to turn off the LASER and return to the Settings menu
- Refer to User Guide page 20 for troubleshooting if LASER is not visible

8. Select Detector

- Select Detector to be accessed
- All Detectors need to be aligned separately
- Steps 9 to 12 explain how to align individual Detectors

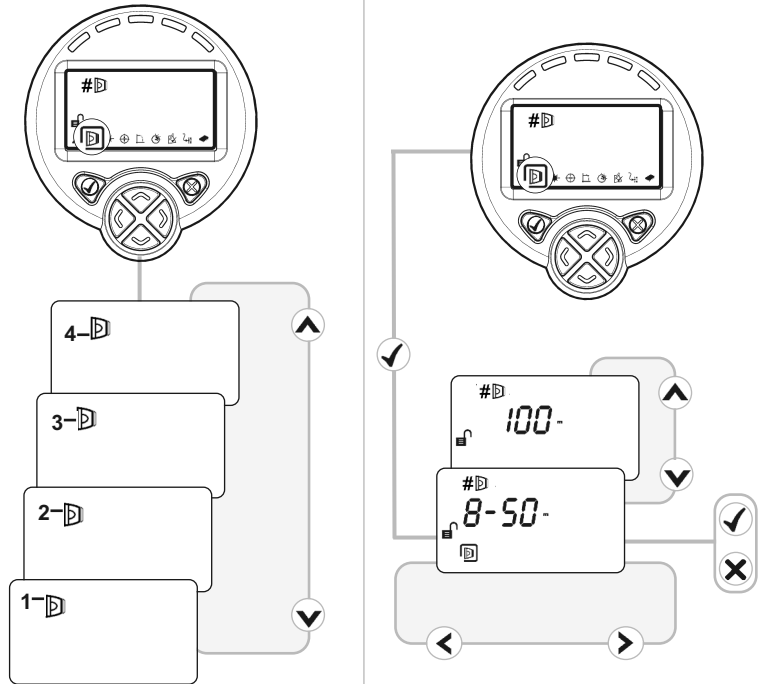

9. Select Distance between Detector and Reflector

- Select 8-50m (default) or 100m
- It is possible to set the range of each individual Detector

11. 'Auto' Alignment

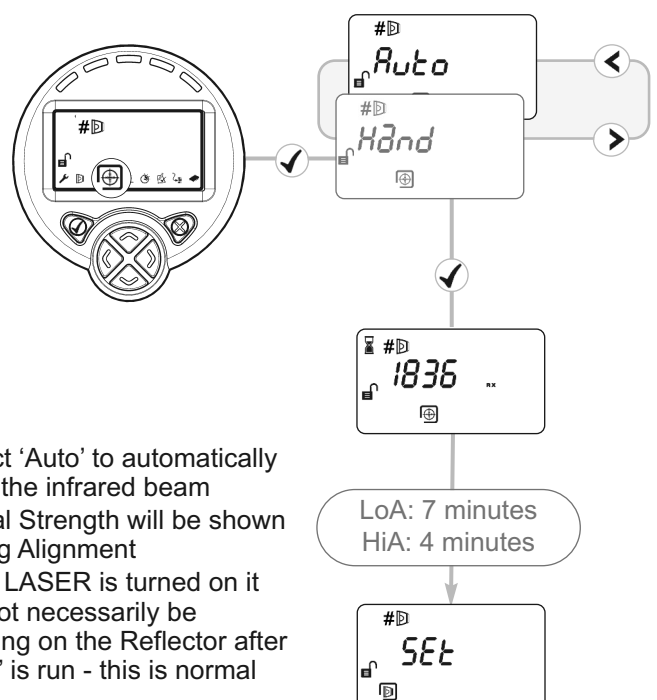

12. 'Set' 0/100 (Calibrate)

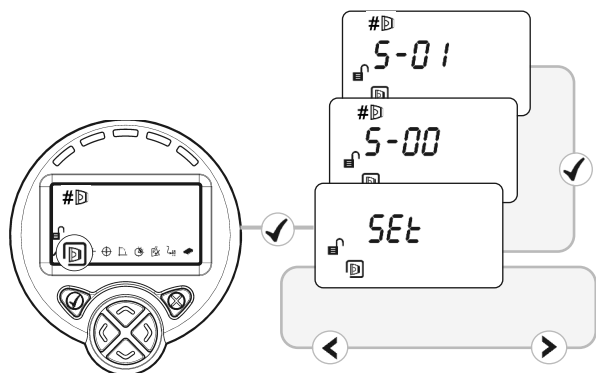

- When 'Set' is displayed press ✓
- When 'S-00' is displayed, cover the Reflector with a non-reflective material and leave covered, then press ✓
- When 'S-01' is displayed, uncover the Reflector and leave uncovered, then press ✓
- Repeat Steps 8 to 12 for any other Detectors found during the 'Find' process

13. System is Aligned

- It is recommended to set the system back to 'Lo A' mode
- Green LED on Detector will flash every 10 seconds, and Signal Strength should be between 99% and 101%
- Default values: 35% Fire Threshold, 10 second delay to Fire and Fault, Non-Latching mode
- Refer to User Guide page 13-14 to change settings and for Fire and Fault Test

Troubleshooting

E-01	Detector Not Found System Controller could not find Detector. Also displayed during power up	<ul style="list-style-type: none"> • Wait 45 seconds for system to power up • Check wiring between System Controller and Detector (Voltage to Detector should be 11—13V)
E-02	Detector is connected but not 'Found'	<ul style="list-style-type: none"> • Follow 'Find' process and align if necessary
E-08	Compensation Level Not Zero Compensation must equal zero when 'Set' is selected	<ul style="list-style-type: none"> • Re-align Detector using Auto-Align
E-09	Signal Strength Out of Range Signal Strength is too low or too high after Auto-Align	<ul style="list-style-type: none"> • Ensure correct distance has been set • Ensure correct Reflector type has been used • Ensure clear line of sight to Reflector • Re-align Detector using LASER and Auto-Align
E-10	Reflector Not Found Detector could not align with Reflector	<ul style="list-style-type: none"> • Ensure correct distance has been set • Ensure correct Reflector type has been used • Ensure clear line of sight to Reflector • Re-align Detector using LASER and Auto-Align
E-11	Auto-Align Failed	<ul style="list-style-type: none"> • Ensure correct distance between Reflector and roof structures • Ensure clear line of sight to Reflector • Re-align Detector using Auto-Align
E-12	Cannot Zero During 'S-00' in 'Set' The Reflector was not covered or the Detector was not aligned onto the Reflector	<ul style="list-style-type: none"> • Ensure Reflector was completely covered with a non-reflective material • Re-align Detector using Auto-Align
E-13	No Signal During 'S-01' in 'Set' The Reflector was not uncovered during 'S-01'	<ul style="list-style-type: none"> • Ensure Reflector was uncovered when 'S-01' was selected
E-14	'Centre' Stage of Alignment Failed Detector has aligned on something other than the Reflector	<ul style="list-style-type: none"> • Ensure clear line of sight from Detector to Reflector for a radius of 0.5m

14. Check Alignment Status Displays

A commissioned system will display:

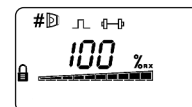

When Detectors have been found but the selected Detector is not aligned the system will display:

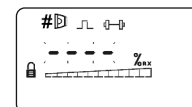

When a Detector is connected but not 'Found' the system will display:

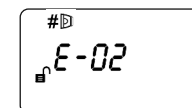

Approval Information

European Approval Information

Complies with EN54-12 for sensitivity levels between 25% and 35% with a maximum delay to fire of 20 seconds.