

Commissioning

It is important that the system be fully tested after installation. In normal operating conditions, apply short-circuits to the supply wiring at various points to confirm the isolators are functioning correctly. Ensure that any applicable local codes are adhered to.

LED Indicators

Yellow LED illuminated if a short-circuit is detected either side of the isolator.

Troubleshooting

Before investigating individual units for faults, it is very important to check that the system wiring is fault free. Earth faults on a data loop or any ancillary zone wiring may cause communication errors.

Many fault conditions are the result of simple wiring errors.

Fault finding

	Problem	Possible Cause
	LED illuminated constantly	Short circuit on loop wiring Wiring reverse polarity Too many devices between isolators
	Failure to isolate a short circuit	Incompatible control panel Incorrect wiring



Marine Negative Switching Isolator Installation Guide

General

Marine isolators and isolating bases are designed to sense and isolate short-circuits on Discovery Marine loops.

The Marine Isolator, part no 55000-721MAR, is a stand-alone device which is fitted into its own base, part no 45681-211MAR.

Marine Isolating Base, part no 45681-286MAR, is used in place of standard Discovery Marine bases and contain the same isolating circuitry as the stand-alone device.

Mounting

Marine isolators and isolating bases are loop powered and polarity sensitive and can be damaged if connected in reverse polarity. It is important to note the polarity is indicated at the wiring terminal.

Mounting the Marine Isolator Base (part no 45681-211MAR)

1. Secure the isolator base to an even surface.
2. Connect wiring following the diagram overleaf.
3. Ensure earth continuity is maintained using the earth terminal on the base if required.
4. Fit isolator, part no 55000-721MAR, into the isolator base.

Mounting the Marine Isolating Base (part no 45681-286MAR)

1. Secure the base to an even surface.
2. Note that the base had a raised profile which serves as a detector LED locator.
3. Connect the wiring following the diagram overleaf.
4. Ensure earth continuity is maintained using the earth terminal on the base if required.
5. Program the address card. See table overleaf for address data.
6. Fit the appropriate detector.

Wiring Details

All wiring terminals will accept solid or stranded cables up to 2.5mm².

Circuit with Isolators

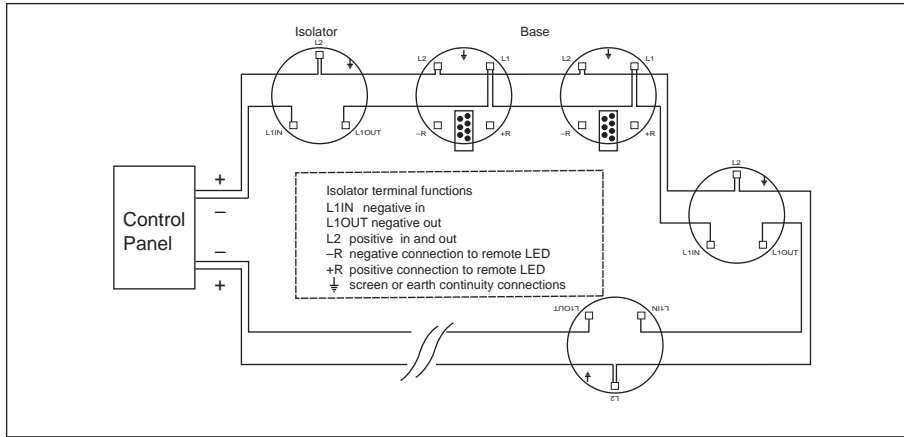

Circuit with Isolating Bases

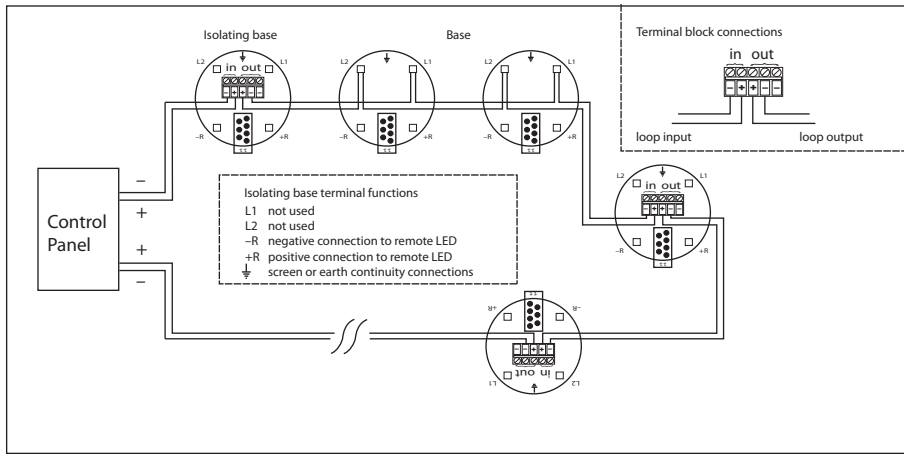

For a full technical specification of Isolators and isolating bases, please refer to the Isolators and Isolating Bases PIN Sheet, PP2090.

Address Setting

Select the desired address and remove the pips indicated in black. Remove pips with a small screwdriver.

