

Commissioning

It is important that the system be fully tested after installation. In normal operating conditions, apply short-circuits to the supply wiring at various points to confirm the isolators are functioning correctly. Ensure that BS5839 Part 1 and any applicable local codes are adhered to.

LED Indicators

Yellow LED illuminated if a short-circuit is detected either side of the isolator.

Troubleshooting

Before investigating individual units for faults, it is very important to check that the *system* wiring is fault free. Earth faults on a data loop or any ancillary zone wiring may cause communication errors. Many fault conditions are the result of simple wiring errors.



Fault finding

Problem	Possible Cause
LED illuminated constantly	Short-circuit on loop wiring. Wiring reverse polarity. Too many devices between isolators.
Failure to isolate a short-circuit	Incompatible control panel. Incorrect wiring.

XP95 Positive Switching Isolator Installation Guide

General

XP95 Isolators and isolating bases are designed to sense and isolate short-circuits on XP95 and Discovery loops.

The XP95 Isolator, part no 55000-710, is a stand-alone device which is fitted into its own base, part no 45681-211.

XP95 Isolating bases, part no 45681-323, are used in place of standard XP95 or Discovery bases and contain the same isolating circuitry as the stand-alone device.

Mounting

Isolators and isolating bases are loop powered and polarity sensitive and can be damaged if connected in reverse polarity. It is important to note the polarity is indicated at the wiring terminal.

Mounting the Isolator base (part no 45681-211)

1. Secure the isolator base to an even surface.
2. Connect wiring following the diagram overleaf.
3. Ensure earth continuity is maintained using the earth terminal on the base if required.
4. Fit isolator, part no 55000-710, into the isolator base.

Mounting the Isolating base (part no 45681-323)

1. Secure the base to an even surface.
2. Note that the base had a raised profile which serves as a detector LED locator.
3. Connect the wiring following the diagram overleaf.
4. Ensure earth continuity is maintained using the earth terminal on the base if required.
5. Program the address card. See table overleaf for address data.
6. Fit the appropriate detector.

Circuit with Isolators

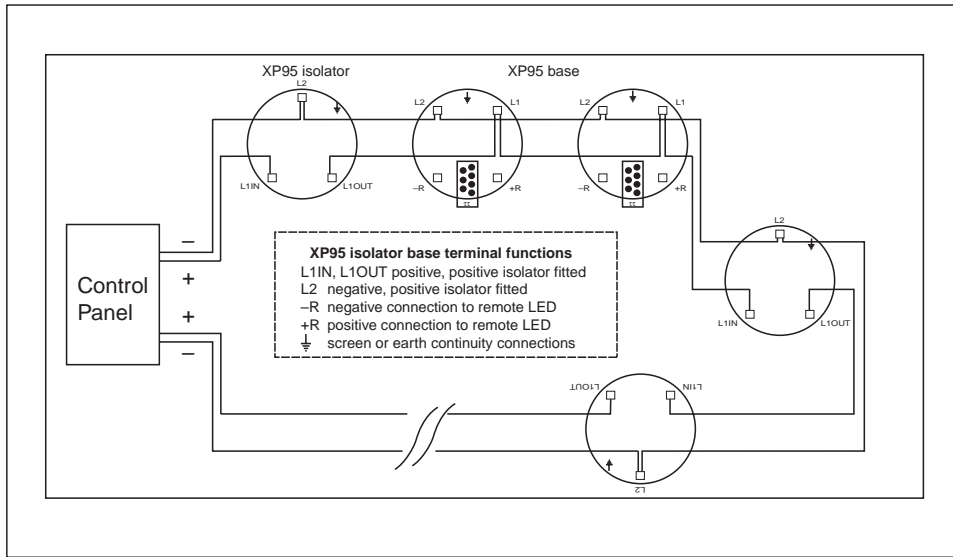

Circuit with Isolating Bases

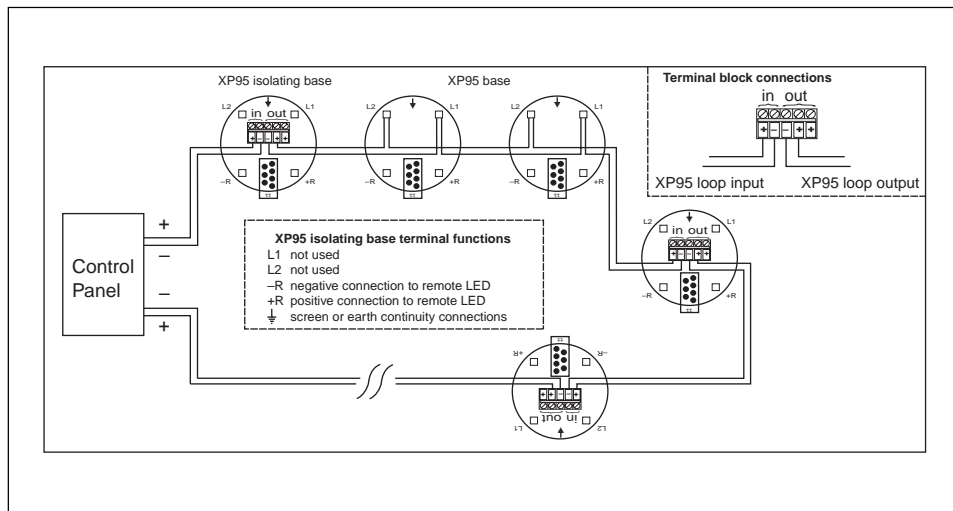

Wiring Details

All wiring terminals will accept solid or stranded cables up to 2.5mm²

For a full technical specification of XP95 Isolators and isolating bases, please refer to the XP95 Isolators and Isolating Bases PIN Sheet, PP 2106.

Address Setting

Select the desired address and remove the pips indicated in black. Remove pips with a small screwdriver.

