

XP95 SOUNDER CONTROL UNIT

FUNCTION

The XP95 Sounder Control Unit is used to control the operation of a zone of externally powered sounders and to report their status to Apollo-compatible analogue control equipment.

FEATURES

The Sounder Control Unit allows sounders to be operated continuously or be pulsed, 1 second on, 1 second off. Sounders may be operated individually or in groups and, whichever address mode has been applied, may be synchronised when in pulsed operation.

An opto-coupled input is provided to monitor the state of the external power supply.

In normal operation the Sounder Control Unit returns a pre-set analogue value of 16, but in the event of an open or short-circuit fault or of a fault in the external power supply, the unit returns a pre-set analogue value of 4.

ELECTRICAL CONSIDERATIONS

The unit is line powered and operates at 17–28V DC. It requires a local power supply of 9–50V DC to power the external load, which may be up to 1A.

A polarising diode is required with each alarm device, as sounders are operated by voltage reversal, provided by a double-pole change-over relay. The sounder circuit is protected by a miniature (TR5) fuse rated at 1A.



Part no 55000-823

ADDRESSING

The XP95 Sounder Control Unit responds to its own individual address set with a 7-segment DIL switch. It also responds both to a group address, set by means of a 4-segment DIL switch, and to a pulsed-mode synchronisation address which is embedded in the unit.

Addresses 1 to 111 are used exclusively for individual addresses (if "0" is selected on the DIL switch, the Sounder Control Unit will return a pre-set analogue value of 4 to signal a fault); addresses 112 to 126 are used for group addressing, while the synchronisation address, to which all units respond, is "0". Any Sounder Control Unit on a loop may be freely assigned to a group. The address for any group must be chosen from the range 112–126.



© Copyright Apollo Fire Detectors Limited 1997–2005



INVESTOR IN PEOPLE



Assessed to ISO 9001: 2000
Quality Systems Certificate number 010



36 Brookside Road, Havant, Hampshire PO9 1JR, England.

Tel: +44 (0)23 9249 2412 Fax: +44 (0)23 9249 2754 Website: www.apollo-fire.co.uk Email: sales@apollo-fire.co.uk

Addresses 112 to 126 may be used as individual addresses but only if the 4-segment DIL switch is set to 127 – group addressing is then disabled. If the 4-segment DIL switch were set to any number other than 127, a pre-set analogue value of 4 would be transmitted to indicate a fault.

The Sounder Control Unit is normally polled by its individual address. It responds as described below (See **PROTOCOL BIT USAGE**). If more than one Sounder Control Unit is addressed (by individual or group address) and the sounders are switched to pulsed mode, it is possible for sounders to be out of synchronisation, such that the sounder tone is not distinguishable as “pulsed”.

To prevent this, it is recommended that the pulsed-mode synchronisation address, “0”, be sent either regularly at hourly intervals or once, immediately before energising sounders. The result is that the sounders are synchronised with each other in pulsed mode, 1s on, 1s off. All Sounder Control Units will recognise the “0” address and synchronise their clocks, but they will not return any data to the control panel on such a polling.

NB: Units on two or more loops can be synchronised in pulsed mode only if the panel transmits address “0” to all loops synchronously.

It may be desirable, in alarm conditions, to switch more than one Sounder Control Unit simultaneously. To enable this, units may be drawn together to form a group and given a group address which is common to all Units in the group. When a device recognises its group address, it will process the forward command bits but it will not return any data to the control panel on that address. If it is required to confirm the status of the output bits of devices under group address control, it is necessary to poll all devices in the group by their individual addresses.

PROTOCOL COMPATIBILITY

The unit will operate only with control equipment using the Apollo Series 90, XP95 or Discovery protocol. The features of the XP95 Sounder Control Unit are available only when the unit is connected to a panel with the appropriate software.

PROTOCOL BIT USAGE

The **output (or forward command) bits** from the control panel have the following function:

Output bit 2 is used to apply the required address mode – group addressing or individual addressing.

Group addressing is selected by setting **output bit 2** of the **individual address** to logic 0 on two

or more consecutive cycles and **output bit 2** of the **group address** to logic 1 on two or more consecutive pollings.

All other output bit 2 combinations result in the application of the individual address mode.

Whichever address mode – individual or group – is applied in any polling, the use of the other output bits is identical:

When **output bit 1** is set to logic 1 on two or more consecutive pollings, sounders are pulsed, 1 second on, 1 second off.

When **output bit 0** is set to logic 1 on two or more consecutive pollings, the sounders operate continuously. The sounders will also operate continuously if both output bit 1 and output bit 0 are set to logic 1 on two or more consecutive pollings.

The **seven bits** which are then transmitted by the control panel correspond to the individual or the **group address (as set on the relevant DIL switch)** of the device or devices to be polled. These bits may also be set to zero to enable the unit to respond to the embedded address “0”.

After the Sounder Control Unit has been addressed by the control equipment, it returns data if (and only if) its individual address has been applied. No data is returned when the group address is polled. The response after individual addressing will, however, reflect whatever commands have been set, whether by individual or by group address mode. The response is as follows:

The **interrupt bit** is always set to “0”, logic low.

The **analogue value bits** are set to report a pre-set analogue value of 16 in quiescent condition and 4 during an open or short-circuit fault, an address setting fault or an external power supply fault. A fault cannot be detected when the sounders are operated, since the monitoring circuitry is disconnected and the analogue value transmitted is always 16.

The **input bits** confirm the execution of the commands given by the output bits as follows:

Input bit 2 is set to logic high for group addressing and to logic low if individual addressing has been applied.

Input bit 1 is set to logic low when the sounders are not operated and to logic high to indicate that the sounders have been switched to operate in pulse mode, 1 second on, 1 second off.

Input bit 0 is set to logic low when the sounders are not operated and to logic high when they are operated continuously. If both bits 1 and 0 are set high, this also indicates that the sounders are in continuous mode.

The **type bits** are used to identify the type of unit responding. The type code of the Sounder Control Unit is 001 00 (bits 2, 1, 0, 4, 3). Bits 2, 1 and 0 of the type code are sent immediately after the input bits. The remaining two bits are sent in the XP95 protocol extension.

The **alarm flag** is not placed by the Unit.

The next **two bits** sent are the **extended type code** bits (bits 4, 3) which, in this case, are "00".

The following **five bits**, extension of the analogue value, are not used by the Sounder Control Unit.

The **parity bit** is set to "0" or "1" in the same way as it is by XP95 monitors.

The **final seven bits**, alarm/interrupt address, are not used, since the unit has no alarm reporting function.

FAULT MONITORING

In addition to the monitoring of open and short-circuit faults on the sounder wiring, the Sounder Control Unit has a facility to monitor the presence and polarity of the external power supply to the sounders. This is achieved by a circuit which includes an input to monitor a volt-free contact. This input is accessed by a three-way terminal block to allow normally-open and normally-closed fault contacts. A wire link must be fitted if the fault contact is not used or if a normally-open contact is monitored.

An analogue value of 4 (fault) is transmitted if the polarity is reversed or if the voltage is less than 5V. A fault value is also transmitted in the event of a short-circuit fault (resistance across sounder output $<2k\Omega$) and of an open-circuit fault (resistance across sounder output $>20k\Omega$). An analogue value of 16 (normal) is transmitted if the voltage exceeds 9V. If the voltage is in the range 5–9V, the analogue value may be either 4 or 16, ie, it is indeterminate.

MECHANICAL CONSTRUCTION

The Sounder Control Unit is normally supplied with a backbox for surface mounting. It is also available without the backbox for flush mounting. The mouldings are made from polycarbonate material. Both versions are designed for indoor use only.

Two LEDs, one red, one yellow, are visible through the front cover of the enclosure. The red one pulses or is illuminated continuously to indicate that the sounders are, respectively, pulsed or switched on continuously.

The yellow LED is illuminated whenever a fault has been detected.

Dimensions and weight of Sounder Control Unit (surface mount):

150 x 90 x 48mm 240g

EMC DIRECTIVE 89/336/EEC

The XP95 Sounder Control Unit complies with the essential requirements of the EMC directive 89/336/EEC, provided that it is used as described in this PIN sheet.

A copy of the Declaration of Conformity is available from Apollo on request.

Conformity of the XP95 Sounder Control Unit with the EMC directive does not confer compliance with the directive on any apparatus or systems connected to it.

Schematic Diagram and Wiring Connections

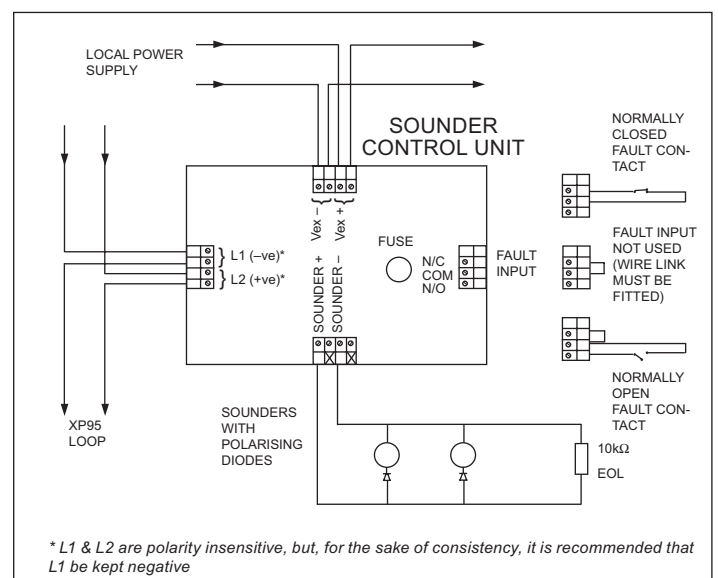

Technical data

Series 90/XP95 loop voltage	17–28V DC
Current consumption, loop, at 24V	
switch-on surge, max 100ms	max 2.6mA
quiescent, 10k Ω EOL fitted to sounder zone	1.9mA
sounders operated	max 1.7mA
fault (yellow LED on)	3.5mA
sounder line short circuit	4.5mA
Current consumption, external supply	
relay off	1mA at 9V 3mA at 32V
sounders and red LED on	44mA at 9V (+ sounder load) 47mA at 32V (+ sounder load)
Sounder output monitoring voltage	9–11V DC (open-circuit condition)
Sounder circuit voltage	max 50V DC
Sounder circuit current, max	1A at 30V DC (inductive or resistive)
Operating temperature	–20°C to +70°C
Humidity (no condensation)	0–95%
Shock	} to EFGS/F/95/007
Vibration	
Impact	
IP rating	54
Radiated emissions	to BS EN 50081–1 & 2
Radiated immunity	to BS EN 50082–1

 CE marked