

Troubleshooting

Before investigating faults with the Mini Monitor Module, check all connections to the unit and the wiring of the system. Many faults are caused by simple wiring errors. Earth faults on a data loop or ancillary zone wiring may cause communication errors. Make sure that the correct value end-of-line resistor is fitted.

Fault Finding

Problem	Possible Cause
No response or missing	Incorrect address setting
Fault reported	Incorrect loop wiring
	Incorrect end-of-line resistor
Analogue value unstable	Dual address
	Loop fault, data corruption
Constant alarm	Incorrect end-of-line resistor
	Incorrect wiring
Incorrect type code	Check position of the priority switch

Technical Data

Operating voltage	20-28V DC
UL listed to operate	17-28V DC
Designed to	24V DC nominal

Current Consumption at 24V

Quiescent current	200µA
LED Operated Alarm	3.4mA + Quiescent
Remote and LED alarm	6.2mA + Quiescent
Switch fault LED	+2.8mA
	(pulsing 0.5s on, 0.5s off)

Notes:

1. The Mini Monitor Module is not designed for outdoor use.
2. All circuits are power limited.
3. The unit must be installed in Outlet Box, part no 45681-520 or in a dedicated suitable UL listed enclosure, employing only power limited circuits.

©Apollo Fire Detectors Ltd. 2010

Apollo Fire Detectors Ltd., 36 Brookside Road, Havant, Hants, PO9 1JR, UK
Tel +44 (0)23 9249 2412 Fax +44 (0)23 9249 2754
Email: techsales@apollo-fire.co.uk Website: www.apollo-fire.co.uk

In the USA: Apollo America, 821 Ulrich Ave, Louisville, KY 40219
Tel: (502) 964-6565 Fax: (502) 964-6229
Email: infoUSA@apollo-fire.com Website: www.apollo-fire.com



Mini Monitor Module Installation Guide

General

The Mini Monitor Module, part no 55000-765, is a loop-powered device, which incorporates a monitored input circuit for connection to switches. The module is supplied in a small housing designed to fit into an electrical box, or to be DIN Rail mounted.

The Mini Monitor Module, has an optional priority interrupt facility to give fast response and can be fitted in an electrical box behind a pull station. This option is selected via the eighth section of the DIL switch.

Please note: When the eighth section of the DIL switch is changed, the Mini Monitor Module will change the type code it sends to the panel.

Control Panel Compatibility

Compatibility Identifier number: 55000-765. The module has been approved by Underwriters Laboratories Inc. For details of compatible control panels contact Apollo Fire Detectors.

Installation

The Mini Monitor Module, part no 55000-765, monitors the state of one or more single-pole volt-free contacts and may be used in installations where space is limited.

1. Connect loop wiring to the SEMS terminals as shown in **Fig 1**.
2. Set the address using the DIL switch in accordance with the address table overleaf.
3. The eighth section of the DIL switch is used for setting the priority of the unit. Set to '1' for priority and set to '0' for non priority.
4. See **Fig 1** for wiring options.
5. Use solid conducted wire only.
6. Supplied resistors are for test purposes only.

There are three mounting options for this module:

1. 2 x 3/32" screws at 1 1/8" centres.
2. The unit can be attached to a standard 1 3/8" DIN rail, see **Fig 2**. To remove device, lift the releasing clip and turn the unit anti-clockwise.
3. Installed in Outlet Box, part no 45681-520.

The Mini Monitor Module has three status LEDs:

- Red Indicates alarm condition
- Green Indicates normal polling

Note: Remote polling indication is achieved by connecting an LED across terminals three and four.

- Yellow pulsing, trouble on the monitored circuit

Wiring options for the Mini Monitor Module

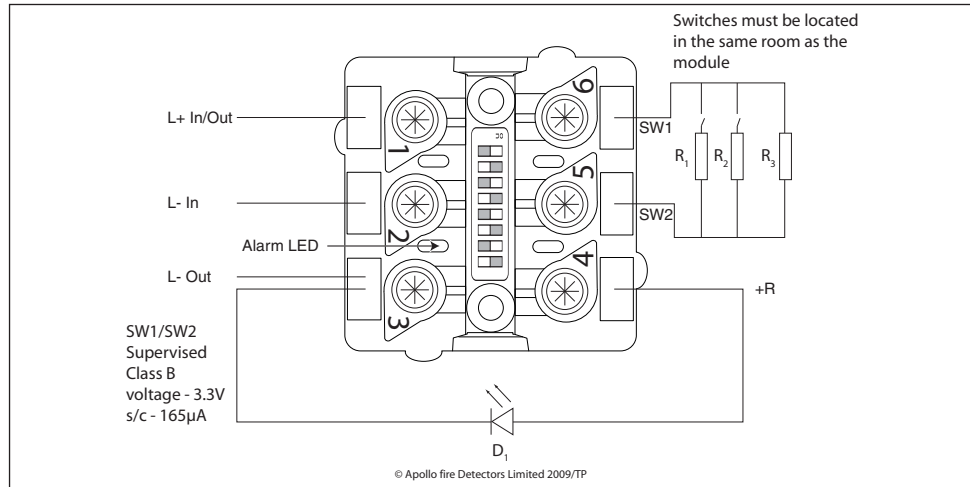

Fig. 1 – Connections to the Terminals.

Key

- R₁ Alarm Short circuit
- R₂ Pre-Alarm 10KΩ
- R₃ End of Line 20KΩ
- D₁ Optional Remote LED

Use UL listed resistors rated 10k for pre-alarm and 20k for end-of-line

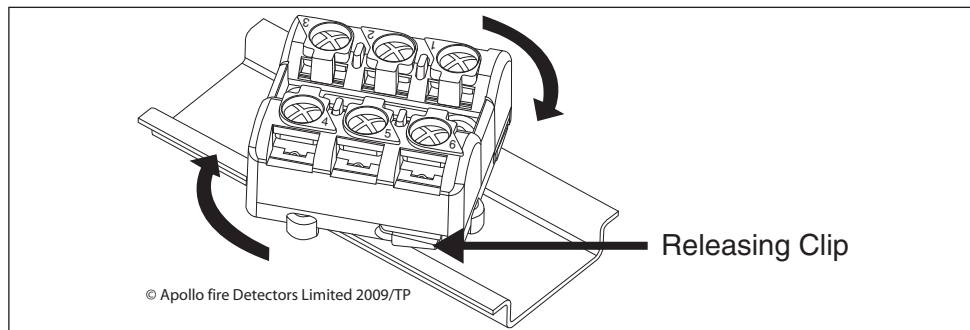
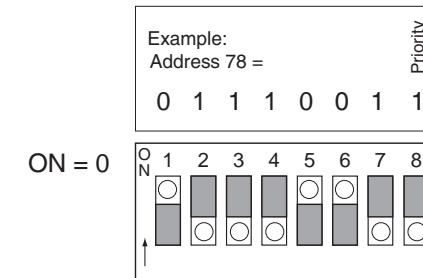

Fig. 2 – Mini Monitor Module on a DIN Rail.

Address Setting

The address of the Mini Monitor Module is set using the first seven segments of the DIL switch. Each segment of the switch must be set to "0" or "1", using a small screwdriver or similar tool. A complete list of address settings is shown below.

DIL switch setting 1234567		DIL switch setting 1234567		DIL switch setting 1234567		DIL switch setting 1234567		DIL switch setting 1234567	
addr		addr		addr		addr		addr	
1	1000000	11	1101000	21	1010100	31	1111100	41	1001010
2	0100000	12	0011000	22	0110100	32	0000010	42	0101010
3	1100000	13	1011000	23	1110100	33	1000010	43	1101010
4	0010000	14	0111000	24	0001100	34	0100010	44	0011010
5	1010000	15	1111000	25	1001100	35	1100010	45	1011010
6	0110000	16	0000100	26	0101100	36	0010010	46	0111010
7	1110000	17	1000100	27	1101100	37	1010010	47	1111010
8	0001000	18	0100100	28	0011100	38	0110010	48	0000110
9	1001000	19	1100100	29	1011100	39	1110010	49	1000110
10	0101000	20	0010100	30	0111100	40	0001010	50	0100110
51	1100110	61	1011110	71	1110001	81	1000101	91	1101101
52	0010110	62	0111110	72	0001001	82	0100101	92	0011101
53	1010110	63	1111110	73	1001001	83	1100101	93	1011101
54	0110110	64	0000001	74	0101001	84	0010101	94	0111101
55	1110110	65	1000001	75	1101001	85	1010101	95	1111101
56	0001110	66	0100001	76	0011001	86	0110101	96	0000011
57	1001110	67	1100001	77	1011001	87	1110101	97	1000011
58	0101110	68	0010001	78	0111001	88	0001101	98	0100011
59	1101110	69	1010001	79	1111001	89	1001101	99	1100011
60	0011110	70	0110001	80	0000101	90	0101101	100	0010011
101	1010011	106	0101011	111	1111011	116	0010111	121	1001111
102	0110011	107	1101011	112	0000111	117	1010111	122	0101111
103	1110011	108	0011011	113	1000111	118	0110111	123	1101111
104	0001011	109	1011011	114	0100111	119	1110111	124	0011111
105	1001011	110	0111011	115	1100111	120	0001111	125	1011111
								126	0111111



© Apollo Fire Detectors Limited 2006-7/DJO/TP